

Solar Shading Systems

Architectural Envelope

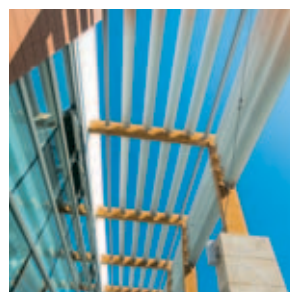

Solar Shading Systems



Features

- 6063-T5 Aluminum Alloy Extrusions
- Min. Elliptical Section: 100 mm [4"]
- Max. Elliptical Section: 450 mm [17³/₄"]
- Hardware fits aluminum, steel, or glass blades
- Max. Glass Blade Thickness: 14 mm [1/2"]
- Max. Profile Length: 6500 mm [256"]
- Custom Color
- Painted or Anodized Finish
- Fixed or Mobile Blades
- System complements Poliedra-Sky 60 Curtain Wall
- Vertical and Horizontal Configurations
- Remote Controlled System

Benefits

- Thermal Insulation
- Acoustic Insulation
- Aesthetic Features
- Easy Maintenance

Applications

- Low and Mid-Rise Buildings
- Storefronts
- Skylights

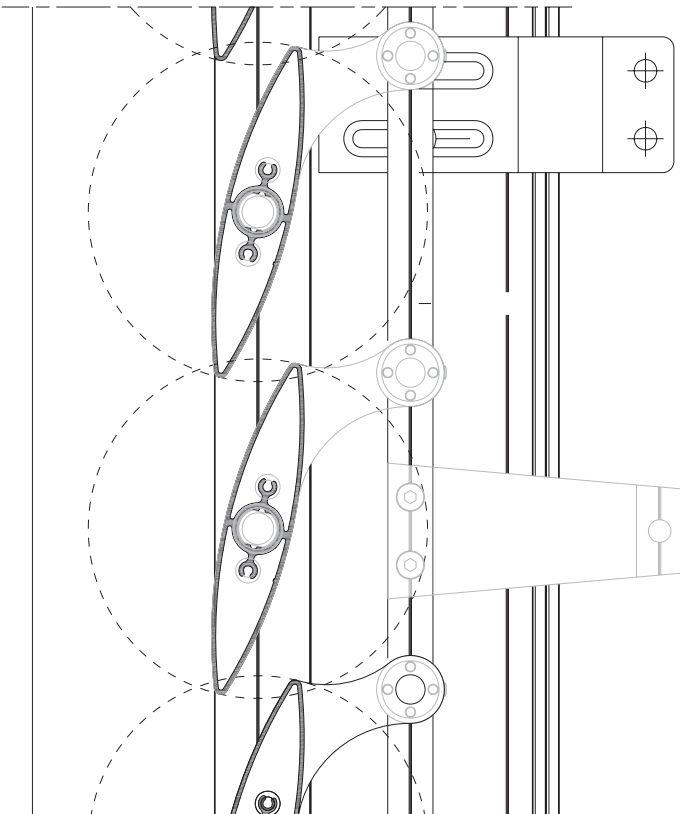

Technology

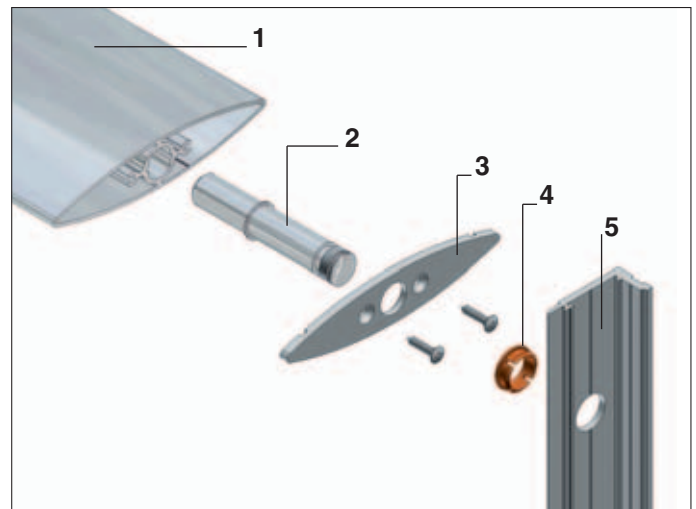

- 1- Extruded Blade
- 2- Stainless Steel Shaft
- 3- Aluminum Cap
- 4- Plastic Ring
- 5- Extruded Support

Configurations

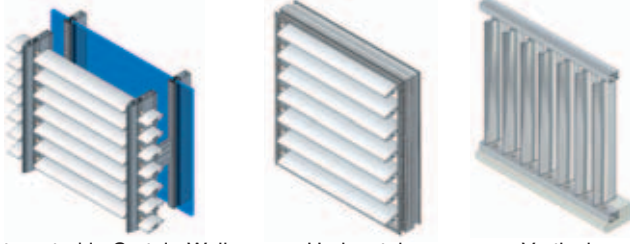

Integrated in Curtain Wall

Horizontal

Vertical

Solar Architecture

Buildings in North America are exposed to harsh climates. METRA Solar Shading Systems provide weather protection, create interior comfort, let in light, and allow for exterior views.

METRA Sunblades are made of extruded aluminum profiles. Durability and easy maintenance are key features of our products.

METRA Sunblades can be installed as an independent structure or connected to the main façade system, and they can be painted in virtually any color.

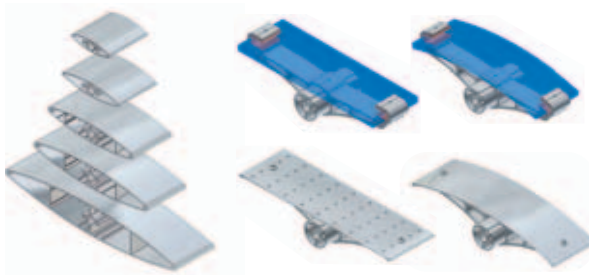

Design

The interface between interior and exterior must be seen as a dynamic system, which responds to the permanent variability in external radiation, climate conditions, and internal requirements.

Main parameters for designers:

- Structural and Thermal Loads
- Surface Finish
- Exposed Surfaces
- Solar Zoning
- Selective Shading
- Utilization of Storage Masses

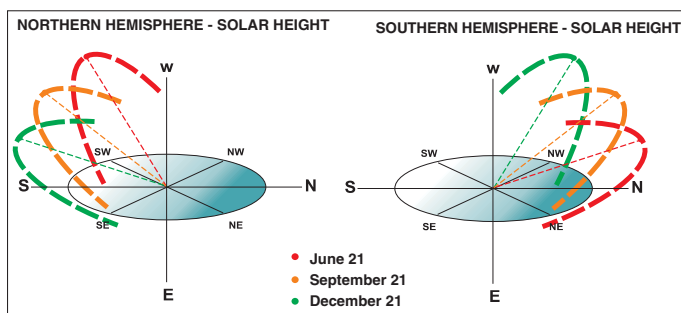

Quality

METRA stands for quality and optimal performance.

Only original METRA profiles and accessories can certify the highest performance. Original METRA products have an "M" mark on the interior surface.

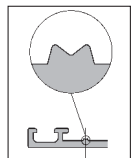

METRA quality is certified by ISO 9001.

METRA controls the entire process of production for the extrusions.

Manufacturing and installation of final products are performed through a network of independent specialists.





METRA Systems
1995 Industrial Blvd. - Laval, QC H7S 1P6, Canada
Tel. +1 450 629 1806 - Fax +1 450 629 7313
info@metrasystem.com
www.metrasystem.com



METRA
METRA S.p.A.
Via Stacca, 1 - 25050 Rodengo Saiano (BS) Italy
Tel. +39 030 6819.1 - Fax +39 030 6819 990
metra@metra.it
www.metra.eu

METRA Products

Architectural Envelope

Entrances & Windows

Special Systems

Sliding Systems

Accessories

Printed in September 2008